

FAFK-190

(voltage, current, torque, etc free customization)

典型应用 Typical Applications:		轴长 Shaft Length A(mm)
智能指纹锁、减速电机、 电动剃须刀、电动推剪	Intelligent fingerprint lock, gear motor, electric shaver, cutter	Customizable



外形尺寸 DIMENSION

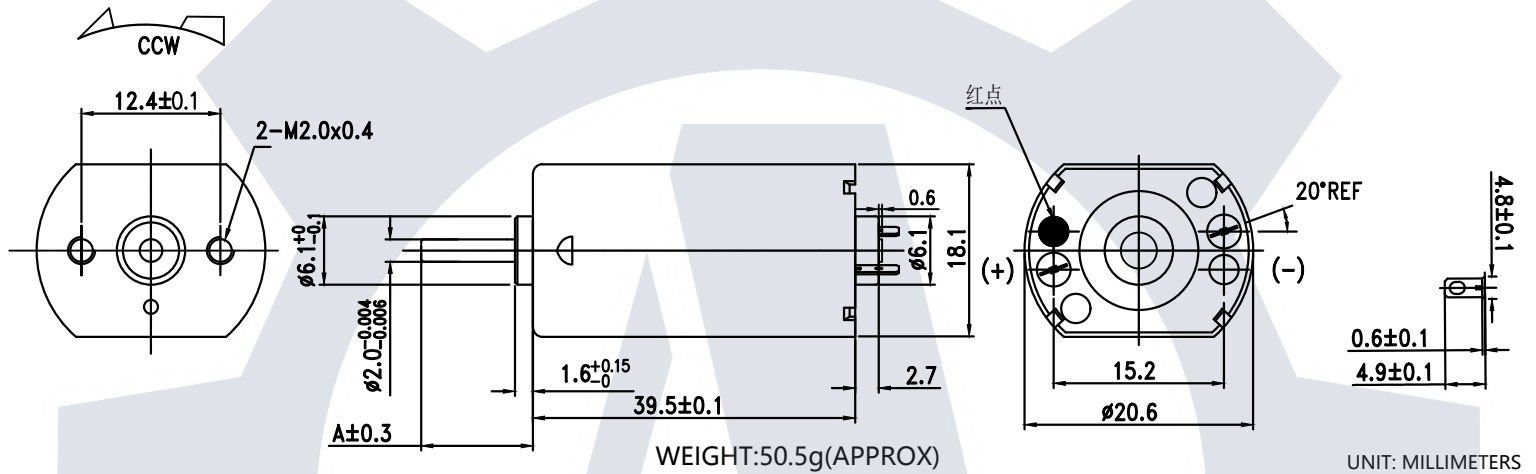

微型直流有刷电机性能曲线图

Micro brush DC electric motor performance curve

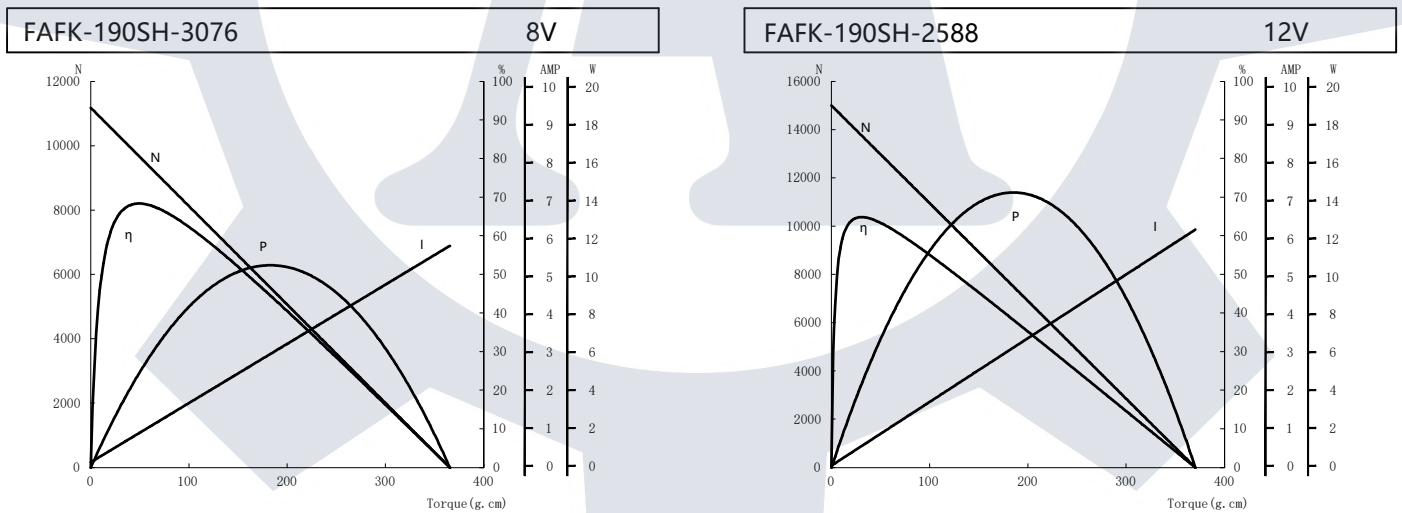

微型有刷直流电机性能参数表 Micro brush DC electric motor data table

型号 Model	电压 Voltage		空载 No Load		额定负载 RATED LOAD						堵转 Stall		
	适用范围 Operating range	额定 Rated	转速 Speed	电流 Current	转速 Speed	电流 Current	扭矩 Torque	输出功率 Output	效率 Efficiency	扭矩 Torque	电流 Current		
	VDC		RPM	A	RPM	A	mN.m	gf.cm	W	%	mN.m	gf.cm	A
FAFK-190SH-3076	6.0-12.0	8	11180	0.138	9679	0.89	4.81	49.06	4.88	68.5	35.83	365.5	5.74
FAFK-190SH-2588	8.0-15.0	12	15000	0.05	13760	0.555	3.00	30.61	4.32	64.9	36.31	370.4	6.16