

# FARS-795 (voltage, current, torque, etc free customization)

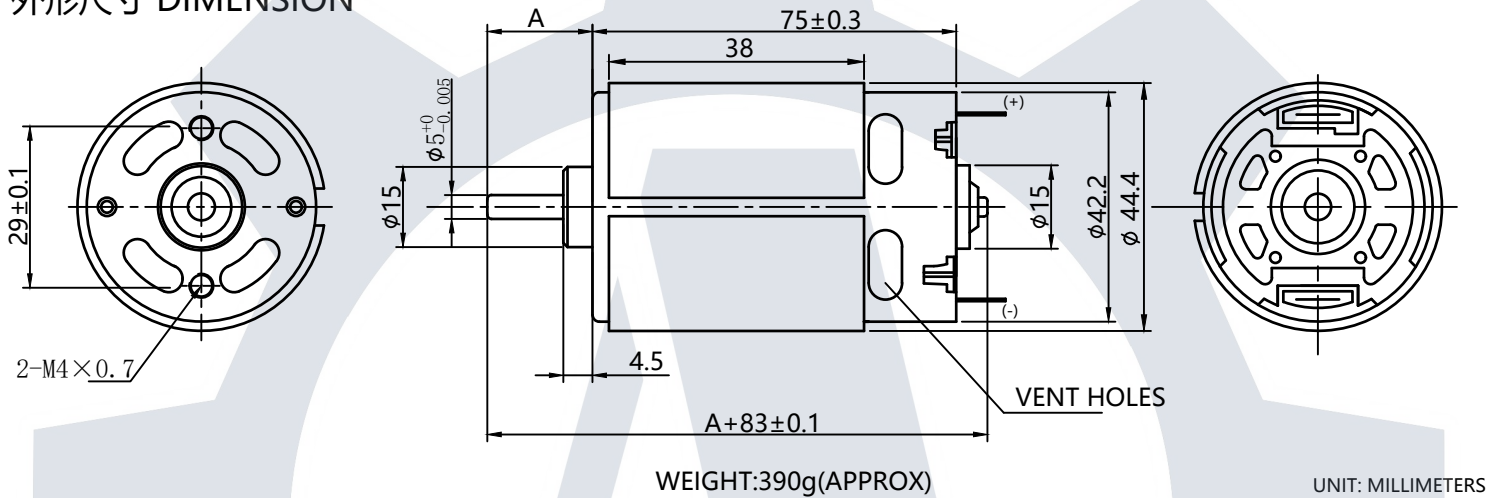

典型应用 Typical Applications:		轴长 Shaft Length A(mm)
自动售货机、自动化产品、 电动按摩器	Automatic vending machine, Automotive product, Massager	Customizable

## 外形尺寸 DIMENSION



## 微型直流有刷电机性能曲线图

### Micro brush DC electric motor performance curve

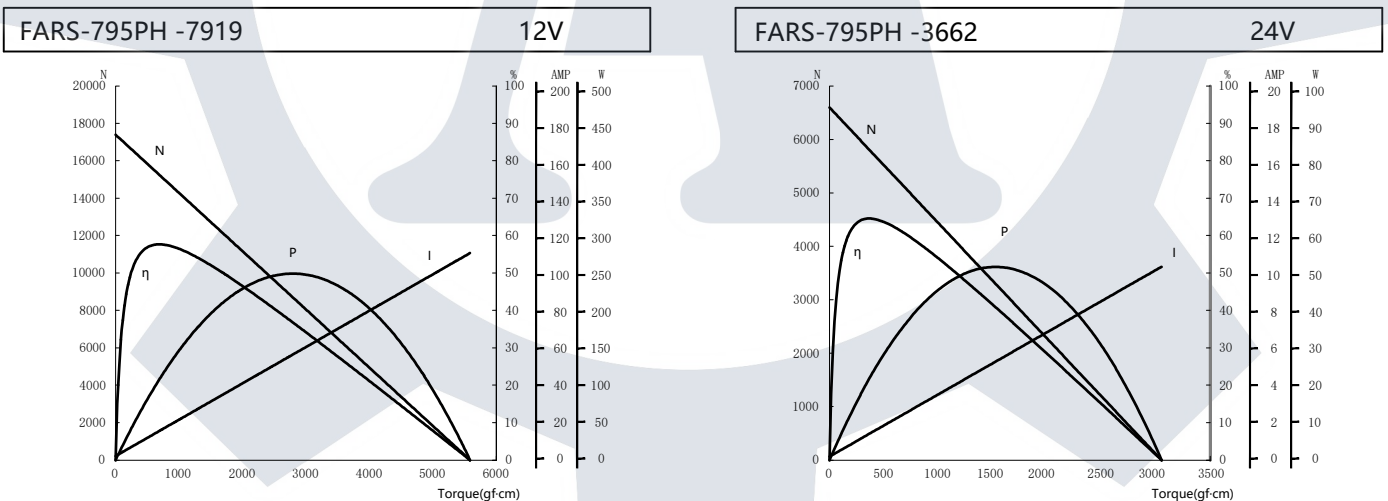

## 微型有刷直流电机性能参数表 Micro brush DC electric motor data table

型号 Model	电压 Voltage		空载 No Load		最高效率点 At Max Efficiency					堵转 Stall			
	适用范围 Operating range	额定 Rated	转速 Speed	电流 Current	转速 Speed	电流 Current	扭矩 Torque	输出功率 Output	效率 Efficiency	扭矩 Torque	电流 Current		
	VDC		RPM	A	RPM	A	mN·m	gf·cm	W	%	mN·m	gf·cm	A
FARS-795PH -7919	6.0-24.0	12	17400	2.19	15255	15.57	67.55	689	107.91	57.8	547.84	5588	110.7
FARS-795SH -3662	9.0-26.0	24	6600	0.19	5812	1.4	35.73	364.4	21.74	64.7	299.26	3052.5	10.34