

FABL1625 | 0.1~4W | Weight: 20g (APPROX)

Rated Voltage from 6V to 30VDC, Speed, torque, etc. free customization.

·典型应用 Typical Use

个人护理(Personal Care)
家用电器(Home Application)
电动工具(Power Tools)
商业设备(Business Equipment)
医疗器械(Medical Apparatus)

·连接端口 Connector Interface

Number	Function
1	VCC
2	FG
3	CW/CCW
4	GND
5	PWM

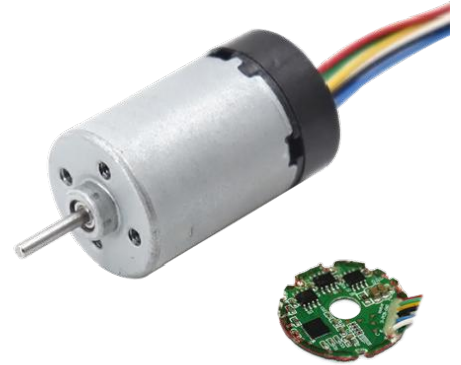
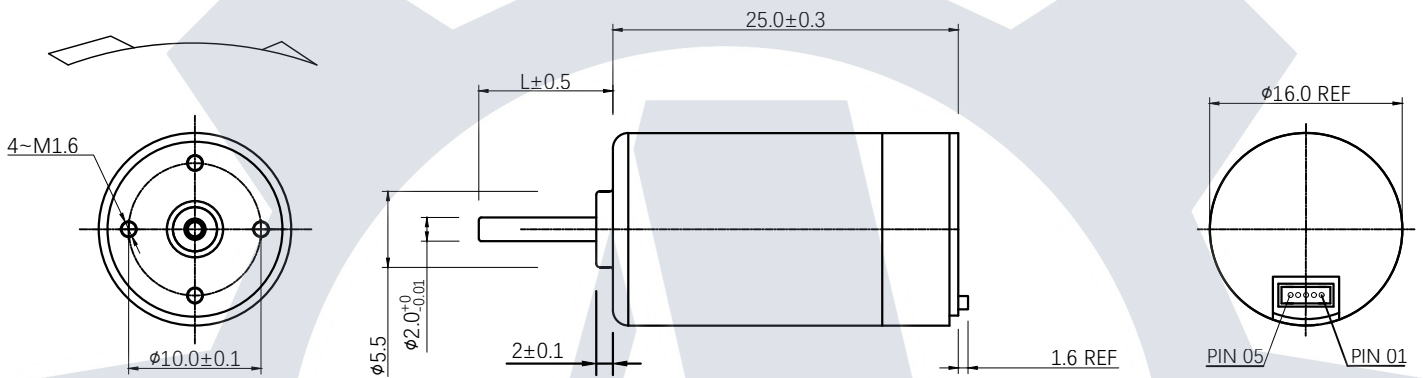
DIRECTION OF ROTATION

Shaft Length "L" can be customized charge-free, shaft shape can be also customized accordingly.

UNIT:MM

MODEL	VOLTAGE		NO LOAD		AT MAXIMUM EFFICIENCY				STALL	
	OPERATING RANGE	RATED	SPEED	CURRENT	SPEED	CURRENT	TORQUE	OUTPUT	TORQUE	CURRENT
			r/min	A	r/min	A	g. cm	W	g. cm	A
FABL1625-V1	5V~9V	6V	9800	0.055	7940	0.228	11.31	0.908	58.7	0.965
FABL1625-V2	5V~12V	9V	8020	0.03	6256	0.1	9.1	0.587	41.6	0.362
FABL1625-V3	8V~16V	12V	8400	0.023	6640	0.086	9.6	0.655	45.8	0.321

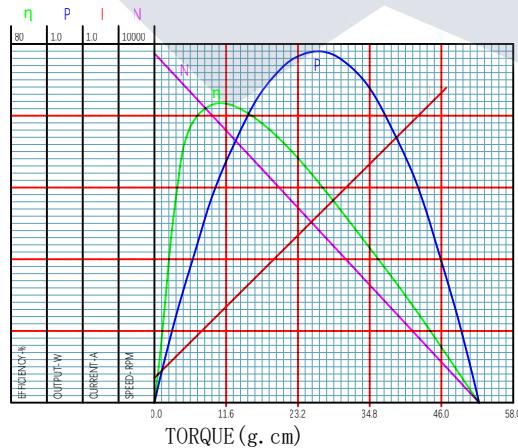
FABL1625-V1 6V

FABL1625-V3 12V
